

Provided by RDO Equipment Co.

SUMMER / 2020

WORKSITE

journal



1970-2020



ONLINE NOW:

LEARN MORE BY WATCHING THESE VIDEOS AT:
JohnDeere.com/worksitejournal

50-YEAR JOURNEY

Relive the evolution of John Deere skid steers from simple hauling machines to essential iron.

TRIED & TRUE

Learn why Mark Whitesell, owner of True Value Rental®, loves the rental business — and Deere Compact Construction Equipment.

LETTER FROM JUAN

CELEBRATING A HALF-CENTURY OF JOHN DEERE SKID STEERS



At CONEXPO-CON/AGG® 2020 this past March in Las Vegas, we proudly displayed a completely refurbished Model 24, the first John Deere skid steer, introduced in 1970. As you'll learn in the article on page 8, our machines have evolved quite a bit from "mechanized wheelbarrows." Yet when I saw the Model 24 at CONEXPO, I was struck at how big it was. We've come a long way in terms of performance, creature comforts, and technology, but put a bucket, forks, or grapple on a Model 24, and you could get things done. The promise of what these machines could offer was apparent even back then.

The evolution of our skid steer line has been driven above all by our desire to meet the needs of our customers. In the mid-1990s, we formed our first formal Customer Advocate Group (CAG) to get input for designing our 200-Series. In 2005, we significantly ramped up these efforts to develop machines based on 100-percent customer input with our D-Series, which featured numerous improvements to cab comfort. Our E-Series machines built upon a great cab while improving uptime and lowering daily operating costs.

Our G-Series lineup of 12 models represents a culmination of all that came before in terms of productivity, cab comfort, and uptime. It also represents a great leap forward in terms of technology, including innovations such as four-way switchable controls, an electrohydraulic (EH) performance package, and JDLink™ machine monitoring.

Like the family sedan, much has changed about our skid steers in 50 years. If an operator could suddenly time-travel from 1970 to 2020, they'd still recognize today's G-Series Skid Steer. But he or she no doubt would marvel at the changes in terms of comfort, performance, and technology. I have no doubt we will continue to develop and manufacture skid steers that meet and exceed our customers' needs and expectations. And I have high hopes for another half-century of innovation for this highly versatile and capable product line.

Juan Raya
Manager,
Global Compact Construction Sales

JOHN DEERE FINANCIAL

NO PAYMENTS / INTEREST
FOR **180** DAYS¹

OR

1.9% APR
FOR 12 MONTHS¹

POWER YOUR CASH FLOW

Put parts, service, attachments, rentals, technology, and more on **PowerPlan™**

JohnDeereFinancial.com

Offer valid on qualifying purchases made between 1 May 2020 to 31 October 2020. Subject to approved credit on PowerPlan, a revolving credit service of John Deere Financial, f.s.b. For commercial use only. After the promotional period, interest charges will begin to accrue at Prime plus 1.5% APR. 1.9% APR is for 12 months only. 0% APR for 180 days and 1.9% APR for 12 months offers require a minimum \$3,000 purchase with at least \$1,000 of the purchase being parts. Repairs must be made to John Deere equipment using John Deere OEM parts. Prior purchases are not eligible. Available at participating dealers. Prices may vary by dealer. CR2 110920 Ltr in U.S.A. (20-03)



IN THIS ISSUE

4 **THE GROUND LEVEL**

The Briar Corporation reaches for its dreams and maneuvers through work in tight spaces with the John Deere 333G SmartGrade™ Compact Track Loader (CTL).

8 COVER STORY **50-YEAR JOURNEY**

Deere skid steers have evolved from a wheelbarrow replacement to a technologically advanced mobile office.

14 **TRIED & TRUE**

With the help of Deere compact construction equipment, Mark Whitesell has run a successful rental company for 20 years.

18 **TECH TIPS**

Gain a competitive edge with our serrated cutting edges, which are perfect for grading and back dragging.

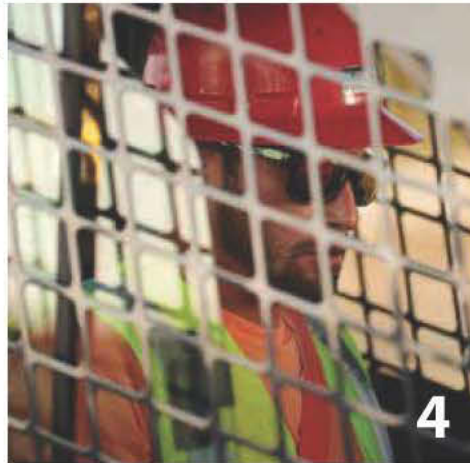

19 **GET CONNECTED**

Use our Bale Hugger to transport, stack, and load large round and rectangular bales.



▶
*The John Deere 333G SmartGrade™
Compact Track Loader exceeds
the expectations of experienced
Briar Corporation Team member
Nelson Brothers.*



BOBBY GOOD CARRIES HIS FATHER'S LEGACY INTO THE FUTURE

The Briar Corporation is one of Central Florida's premier contractors, with a rich history dating back to its 1984 beginnings as a paving and tennis court maintenance company. President Bobby Good has kept his focus on dreams for the future and helping people achieve them since becoming sole owner at the end of 2018.

"Our company's built on great people, and it's the same thing behind the brand. The people behind it are what keeps it going," says Good about taking over the reins from his father. "I've always wanted to chase my father's dreams and expand on them. He told me one time that if the son doesn't grow up to be better than the father, they both have failed."

With almost 340 coworkers running over 100 machines at up to 16 jobsites on any given day, it would be hard to consider the son's leadership of The Briar Corporation a failure by any metric. According to Good, the company has a reputation for being a total-site contractor with a customer base that knows their projects — everything from clearing to earthwork to underground utilities — get done on time, on schedule, and headache free.

As the company has continued to grow and prosper, there has been one constant over the past three-and-a-half decades.

"We've purchased well over a hundred pieces of John Deere equipment in the past

35 years," Good explains. "It's a leading brand in the industry and a brand that we can depend on and trust. We've always had great customer service and relationships, so it's always our go-to machine."

IT TAKES A WHOLE TEAM

The Briar Corporation is known for its tagline "Leaders by Performance", and it takes serious pride in everything it's instilled in its employees. As a profit-sharing company, it's always used the word "coworker" to describe the members of The Briar Corporation family.

"The word 'employee' never felt right to me, because everybody has a responsibility," Good says. "That includes from me all the way down to the guy who's on the shovel in the field."

A different field is where Good gets his sense of teamwork. "I grew up playing sports, and that takes a whole team. When you're playing football, you need everybody to make their blocks to spring the big run, or you need to make the



▲ Bobby Good, president of The Briar Corporation, and Brett Graham, Vehicle Performance Engineer for John Deere, see the myriad capabilities of the 333G SmartGrade CTL.

blocks to make the long touchdown pass. When you get into the site world and you see that everybody has their role and their responsibility, you know everyone's taken care of."

"We are very family oriented when it comes to the Briar Team because no success comes without good people, and we try to give back as much as possible," explains Good. "There are a lot of people that kind of treat their subcontractors and suppliers a certain way, but without them we couldn't do what we do, and we couldn't move more dirt than the competition."

TIGHT WORK

Part of The Briar Corporation's process for building roads is backfilling curbs and rights-of-way, working in very tight spaces around utilities. Oftentimes companies in a similar situation are left having to choose between a smaller dozer without full capabilities or a larger dozer that can't make a job with a tight squeeze look appealing.

—continued



With the addition of the John Deere 333G SmartGrade Compact Track Loader (CTL) to its fleet, that tough decision has disappeared for The Briar Corporation.

“Creating something where you can get into what technically is a skid steer and actually feel like you’re in a dozer is pretty impressive,” remarks Good. “Our guys are jumping in there and feeling like they’re right at home.”

“I’ve been operating skid steers about 15 years at this point,” says Nelson Brothers, a finish grader/skid steer operator on the Briar Team. “We can do things with the 333G SmartGrade that I didn’t think you would ever be able to do with a regular bucket or even a box blade. The machine has a lot of power — when it comes to pushing the dirt, beyond what my expectations were.”

Brett Graham, Vehicle Performance Engineer for John Deere, is equally blown away but maybe not so surprised that the people actually using the 333G SmartGrade are finding it to be a game changer. “It’s a combination of feedback and demand from our customers,” he says. “The 333G SmartGrade is the culmination of all of the things John Deere has learned in grade control from all of our projects going forward from graders, dozers, and excavators, and now CTLs. We put all the things we’ve learned into this package.”

The 333G SmartGrade is purpose built, and one of the big purposes for The Briar Corporation is very precise grading. Instead of eyeballing the situation and needing a coworker to come and check the work, the 333G SmartGrade precisely grades every spot, right down to the smallest one. When it comes to the whole jobsite, with larger areas of general work, the speed and power of the 333G SmartGrade help make everything that much more clean and attractive.

With a bucket, the 333G SmartGrade runs just like a CTL. With a dozer blade and at the click of a button, it transforms into a dozer. The blade-control pattern is familiar to the operator. And the combination of real-time correction and GPS satellite connectivity means the 333G SmartGrade can achieve accuracy down to the millimeter.

“It’s going to be a very universal machine that can work side by side with the bigger machines,” says Good. “It doesn’t surprise me at all that John Deere is kind of the leading brand when it comes to this type of ingenuity. They’ve always been a leader in that market with a focus on the future.”

And for Good and The Briar Corporation, that future is looking better every day.

The Briar Corporation is serviced by Dobbs Equipment LLC, Orlando, Florida.

▶ Briar Team operators Kathryn Helberg and Nicole Sweat on site and ready to work.





WE ARE VERY FAMILY ORIENTED WHEN IT COMES TO THE BRIAR TEAM BECAUSE NO SUCCESS COMES WITHOUT GOOD PEOPLE, AND WE TRY TO GIVE BACK AS MUCH AS POSSIBLE.

– Bobby Good, President, The Briar Corporation



JOHN DEERE 333G
SMARTGRADE™
COMPACT TRACK
LOADER

- ▶ – Rated operating capacity: 1680 kg (3,700 lb.)
- Gross rated power: 74.6 kW (100 hp) at 2,500 rpm
- Net peak power: 72.0 kW (96.6 hp) at 2,500 rpm
- Operating weight (including grade-control hardware and blade): 6350 kg (14,000 lb.)
- Vertical-lift boom for increased lift height and reach at the top of the lift path
- SmartGrade fully integrated grade-control technology installed and ready to work from the factory:
 - 3D grade-control system
 - Dozer-mode electrohydraulic (EH) joystick-control system for dozer functions at the push of a button
 - Six-way dozer-blade attachment for cutting a grade and spreading materials



50-YEAR JOURNEY

Over the last half-century, John Deere skid steers have evolved from mechanized wheelbarrows to highly versatile and productive revenue-generating machines



“It’s been an amazing journey. The product line really evolved out of our desire to listen closely to our customers.”

— GREGG ZUPANCIC,
Product Marketing Manager,
John Deere Skid Steers and
Compact Track Loaders

The humble Model 24 Skid Steer launched a half-century of innovation culminating in the technologically advanced G-Series machines.

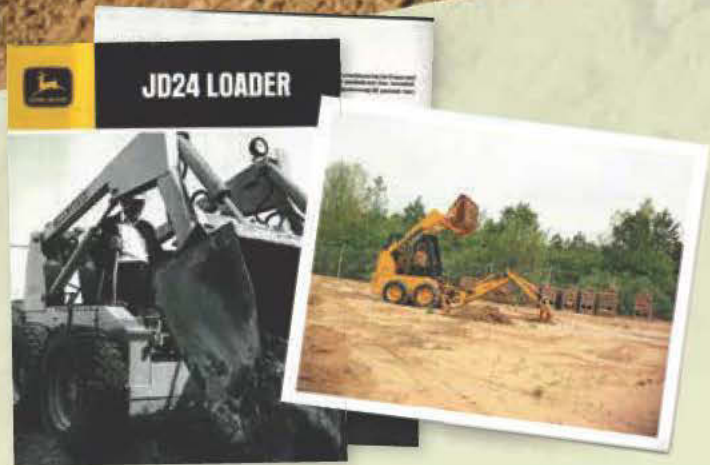

FIFTY YEARS AGO, John Deere came out with its first skid steer loader, the humble Model 24. Early models during the 1970s were geared toward the agricultural and industrial markets. They functioned more or less like a mechanized wheelbarrow replacement. An early ad campaign implored prospective customers to bring a Deere skid steer to their next job and watch the crew smile. Crews no doubt did smile, as skid steers helped reduce backbreaking handwork. Early models offered buckets, forks, and grapple options. Over the decades this product line would evolve into the ubiquitous multi-taskers found seemingly everywhere today with over 100 available John Deere attachments.

Today’s G-Series machines are highly productive, do-it-all mobile offices. A simple rollover protective structure (ROPS) has given way to sealed, spacious four-season cabs complete with multiway adjustable seats, HVAC systems, Bluetooth® radios, and other creature comforts. Hand and foot controls have been

replaced by standard electrohydraulic (EH) joysticks with switchable controls and performance package options. The G-Series lineup comprises 12 models in a variety of sizes, from the diminutive 312GR to the beastly 333G Compact Track Loader (CTL), which customers often refer to as a “mini dozer” and can be equipped with a SmartGrade™ option. With over 100 available John Deere attachments, these highly versatile machines are popular not only with ag and industrial market segments, but with construction, landscaping, and rental as well.

“It’s been an amazing journey,” says Gregg Zupancic, Product Marketing Manager, John Deere Skid Steers and CTLs. “The product line really evolved out of our desire to listen closely to our customers. They were beginning to recognize that these machines could not only offer tons of versatility but could be a real revenue generator for their businesses. Our goal is to provide the right features and options on the right models to reach the largest portion of our market segments.”

'70s

MODEL 24
MODEL 14
70
170
60
90
125



“JD14 replaces wheelbarrows — on any site.”

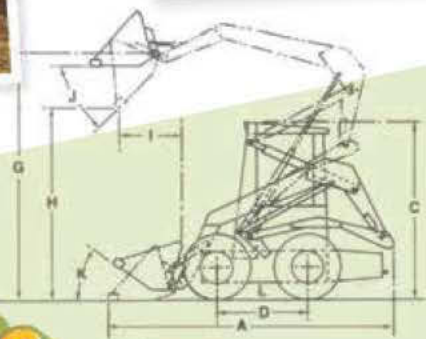

Send JD24-A to your next job and watch the crew smile.
 It's just like to see your crew smile because they're using JD24-A for your next job. The best reason is that it's the most productive on any site.
 We have you for service, too. And our friendly sales, service, and parts staff are on hand to help you with the JD24-A. Call us now.



'80s

75-SERIES:
375
575
675



1970: John Deere offers first skid steer: the 37-hp Model 24.

1972: Deere's second industrial skid steer, the smaller 25-hp Model 14, is introduced. Two green ag versions are also introduced: the 70 (twin of the Model 14) and the 170 (twin of the Model 24).

1979: 60, 90, and 125 models are introduced.

1987: 75-Series (375, 575, and 675) Skid Steers are introduced with Yanmar diesel engines and two new backhoe attachments.

50 YEARS OF INNOVATION

John Deere skid steer technology has evolved much over 50 years in response to customer needs.

MECHANICAL WHEELBARROW

Introduced in 1970, John Deere's first skid steer, the Model 24, delivered bare-bones efficiency. Powered by a 37-horsepower, four-cylinder "Wisconsin" gasoline engine, the machine offered a choice of six buckets, two pallet forks, and a grapple.

Then as now, our customers valued the ability to work in tight spaces. Product literature for the 60, 90, and 125 models in the late 1970s boasted "greater maneuverability in tight, close-quarter areas. These machines are fully at home inside calf pens, milking barns, and poultry houses."

“Work smarter, not harder.”

'90s



75-SERIES II: 200-SERIES
3375
4475
6675
8875



Instant rise in productivity. Just add attachments.

John Deere PowerTech™ Engines
Smooth, quiet four- and five-cylinder HD engines provide powerful, high-torque, fuel-efficient, best-in-class performance and durability.

We... with easy access.

HERE K...

'00s

200-SERIES II
300-SERIES
D-SERIES



“The difference is in



Introducing 2 new skid-steer loaders and 2 new QuickTatch backhoes

My suggestion is...
Do what you need to give me more cab space.

My suggestion is...
WHEN I'M CLEANING STAIRS I NEED TO BE ABLE TO SEE ALL AROUND. **COMPLETED**

1994: 75-Series II (3375, 4475, 6675, and 8875) Skid Steers, which feature John Deere 220-Series engines, are introduced. Fifteen new attachments are available.

1995: First formal Customer Advocate Group (CAG) is formed to get input to develop the 200-Series.

1998: John Deere starts production in the first factory dedicated to skid steers in Loudon, Tennessee. 200-Series machines are introduced.

2001: Skid steer manufacturing moves to our factory in Dubuque, Iowa. 200-Series II is introduced with substantial updates.

LISTENING TO CUSTOMERS

In 1995, the first Customer Advocate Group (CAG) was introduced to get invaluable customer input into developing the 200-Series machines, which would begin production in John Deere's first skid steer-dedicated factory in Loudon, Tennessee, a few years later.

In 2001 production of skid steers was moved to our manufacturing plant in Dubuque, Iowa, an important milestone in the skid steer line.

The 200-Series II featured substantial updates. Customer-inspired innovations included a patented vertical-lift system that provided greater reach than conventional skid steers. The machines also touted superior 360-degree visibility and a unique boom-arm design, enabling a better view to the front attachment.



“Maintenance made ‘E’asy.”



'10s

E-SERIES
G-SERIES



RELIABLE



PRODUCTIVE

“Next ‘G’eneration.”

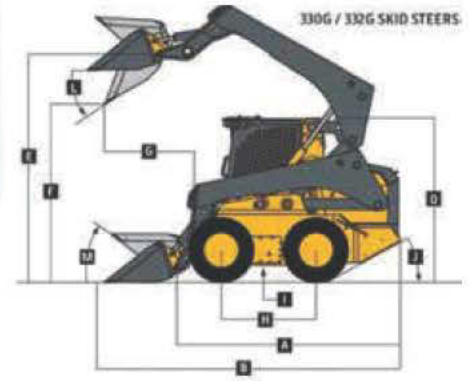

the D-tails.”

2004: 300-Series is introduced, including the smaller new 313 and 315 models as well as CT322 and CT332 CTL models.

2005: CAG efforts significantly ramp up for the D-Series with the goal of delivering 100-percent customer-driven product.

2009: The D-Series is introduced, expanding the lineup to five skid steer models and four CTLs. It was the first skid steer line to be entirely designed and built with state-of-the-art tools and techniques by our quality-conscious workforce in Dubuque.

2013: E-Series is introduced, building on the D-Series in terms of exceptional performance and a great cab environment, with a focus on improving uptime and lowering daily operating costs relative to the engine and powertrain.

100-PERCENT CUSTOMER-DRIVEN PRODUCT

In the mid-2000s, John Deere ramped up CAG efforts, committing to the idea of delivering products that were 100-percent customer driven. The result was the D-Series, the first skid steer line entirely designed and built using state-of-the-art tools and techniques by our quality-conscious workforce in Dubuque. D-Series machines focused on the operator environment.

All-around visibility was substantially more expansive. The pressurized cab was much quieter and added more headroom. Introduced in 2013, E-Series machines built on the D-Series' exceptional performance and cab environment while focusing on improving uptime and lowering daily operating costs.



◀ Electrohydraulic (EH) ISO-pattern joystick.

That was then,

THIS IS NOW

Introduced in 1970, John Deere's first skid steer was surprisingly substantial for its time, weighing in at 4,750 pounds. The machine came with a gasoline engine with a Deere diesel option, in rollover protective structure (ROPS) and non-ROPS versions. The Model 24 boasted simple controls; instant reversing; the ability to turn within its own length; and choice of attachment from six buckets, two pallet forks, or a pulpwood grapple.

SPEC COMPARISON:

1970 vs. 2020

	1970 MODEL 24	2020 332G
Capacity	777 kg (1,700 lb.)	1634 kg (3,600 lb.)
Horsepower	27.5 kW (37 hp)	74.6 kW (100 hp)
Operating Weight	2155 kg (4,750 lb.)	4540 kg (10,000 lb.)



2016: G-Series lineup is expanded to 12 models, with a focus on innovation and automation in technology.

2020: 50th anniversary of John Deere skid steers.

TECHNOLOGICAL MARVELS

In 2016, John Deere introduced its lineup of G-Series Skid Steers and Compact Track Loaders, which now included 12 models. These machines build on everything that came before, with a focus on technology. A major technological innovation is the choice of controls:

- EH ISO-pattern joystick controls come standard on the 330G and 332G (optional on the 320G and 324G).
- Optional ISO-H switchable joystick controls and EH joystick performance package on all models.
- Mechanical foot controls come standard on the 320G and 324G.
- Optional EH four-way switchable controls, including EH foot control, ISO joystick control, H-pattern joystick control, and ISO and foot controls on the 330G and 332G.
- Optional ISO controls with programmable detents with the EH joystick performance package and the EH boom performance package on the 330G and 332G.

John Deere skid steers have come a long way since being used as a wheelbarrow replacement. What will skid steers look like 50 years from now? Remote controlled? Self driving? Drone powered? It's difficult to speculate but exciting to imagine.



Check out the video at:
[JohnDeere.com/worksitejournal](https://www.johndeere.com/worksitejournal)



TRIED

& Prune



**NORTH CAROLINA
RENTAL COMPANY
KNOWS IT CAN DEPEND
ON JOHN DEERE
COMPACT EQUIPMENT**



T rue Value Rental® in Greensboro, North Carolina, has so much John Deere equipment available for rental, it often gets mistaken for a dealer. “We’ll have people come in and ask us to quote them a price,” says Owner Mark Whitesell. “I’ll tell them, ‘Well, I can’t sell you one, but I can rent you one.’ When they come back, I often hear, ‘Wow, I really like this. I own a competitor machine, but next time I’m buying a Deere.’”

Whitesell’s rental company has been thriving in recent years. A large retailer and a number of manufacturing plants have moved into the Triad area of Greensboro, Winston-Salem, and High

Point. A lot of people are relocating to the area because it’s not as expensive as the nearby Research Triangle of Raleigh, Durham, and Chapel Hill.

Whitesell loves the rental business because no two days are the same. “Some days you get up and have nothing on the books, and it turns into the busiest day of the year. Other days you have a million things on the books and you almost dread it, but everything goes off without a hitch and it’s the best day you ever had. Each morning I can’t wait to go into the store to talk with customers. They’re looking for advice, and we’re helping them. It’s very fulfilling.”

—continued



ICONIC BRANDS

Whitesell got started in the rental business in 1997. “I was working for a mechanical contractor owned by two brothers,” he recalls. “They wanted to start their own in-house rental company to rent scissor lifts, pipe machines, and other things a mechanical contractor would need. As we got into it, I thought we should open up to landscapers. That was our first big niche — no one else carried landscaping equipment. In 1999, I went to The ARA Rental Show® (the American Rental Association’s annual convention) and spoke with John Deere, and that’s when we started to carry compact construction equipment, tractors, and mowers.”

In 1999, Whitesell and his business partners cleared five acres of land and opened Grand Rental Station on the site where the company still resides today. In 2017, the company rebranded itself under the True Value Rental name. “We like the True Value brand for the same reason we like John Deere. Both are iconic. Both stand on their own. Our customers request John Deere by name, so we don’t carry other brands of compact equipment.”

Over the years, the company has established a reputation for having newer, well-maintained equipment. Whitesell has rented John Deere equipment since day one. “I’m really proud of our equipment and this store,” says Whitesell. “Back when we started, many rental companies had old equipment. The rule of thumb was to never replace it — just slap some paint on it. That has never been our norm. We wanted the best brands and the latest equipment out there. We’ve had great success with Deere machines.”

EASY TO RUN AND MAINTAIN

In addition to mechanical contractors and landscapers, True Value Rental also rents equipment to homeowners, plumbers, electricians, and other contractors. “For

customers like homeowners, John Deere compact equipment is very easy to run,” says Whitesell.

The company currently rents John Deere 317G and 325G Compact Track Loaders (CTLs), along with 17G, 35G, and 50G Compact Excavators. “These models cover the specs and job needs of every one of our customers,” says Whitesell. “The two CTLs are the perfect size, and people love the traction in wet conditions and how turf-friendly they are.”

The compact excavators are easy to transport and excel in confined spaces. “Landscapers and other small contractors often work up against buildings with tight lot lines and many obstacles. These customers love them.”



“EACH MORNING I CAN’T WAIT TO GO INTO THE STORE TO TALK WITH CUSTOMERS.”

— Mark Whitesell, Owner, True Value Rental



WE WANTED THE BEST BRANDS AND THE LATEST EQUIPMENT OUT THERE. WE'VE HAD GREAT SUCCESS WITH DEERE MACHINES."

– Mark Whitesell, Owner, True Value Rental



RENTAL *Lineup*

True Value Rental carries numerous John Deere attachments for its compact equipment, including forks, a variety of buckets, power rakes, and trenchers. "They are extremely easy to hook up and make the machines so versatile."

Deere compact machines are easy to clean and maintain. On the CTLs for example, two plates can be removed to flush out the footwells, and the cab side windows can be removed for cleaning. Tilting up the hood provides convenient ground-level access to dipsticks, fuel- and fluid-filler necks, and filters.

"They're so easy to clean," says Whitesell. "The plates come off easy, and the grease points are easy to get to. That's important in rental because we need to quickly power-wash the machine, grease it,

and turn it around for the next customer. Getting it back out is the only way we're going to make money."

Uptime is also very important to the rental business. "If I have a customer waiting around for a machine, he's not getting his job done and I'm not getting paid. Fortunately, we've had very few issues with John Deere machines."

Whitesell's local John Deere dealer, James River Equipment, has also been key to keeping his machines up and running. "They are right down the road, they keep the parts we need in stock, and they are

the friendliest people you'll ever meet. The support is just awesome."

Whitesell is grateful for having durable Deere machines in the lot attracting customers and a dependable dealer nearby. "John Deere equipment along with the service and support we get from our local dealer has helped us stay in the rental business for 22 years and be extremely successful."

True Value Rental® is serviced by James River Equipment, Pfafftown and Greensboro, North Carolina.

 Check out the video at:
JohnDeere.com/worksitejournal



COMPETITIVE

EDGE



BOLT-ON SERRATED CUTTING EDGES ARE A CUT ABOVE

Our bolt-on serrated cutting edges are perfect for grading and back dragging. Previously only offered on our 90-inch bucket, they are now available on five other John Deere bucket sizes, ranging from 60 to 84 inches. Optimized to work with Deere skid steers and compact track loaders, they're also compatible with many competitive models.

Read on to learn about how you can best put serrated edges to work for you.

GO WITH THE FLOW

When you need to back-drag unevenly sized material or gravel, use the serrated edge to help improve material flow.

DIG IN

Loading compacted material? Serrations allow easier and more aggressive bucket penetration than a smooth edge.

HOLDING PATTERN

If you're excavating, serrated edges make it easy to hold cut depth.

CATCH YOU ON THE FLIP SIDE

The serrated edge can be flipped over so you can use the smooth cutting edge when preferred.

MAKE A CLEAN SWEEP

Use the smooth edge when you need to clean up the ground.

E



GET — CONNECTED



JOHN DEERE
COMPACT CONSTRUCTION EQUIPMENT
ATTACHMENTS

TECH TIPS

BALE HUGGERS

Looking to tackle a new project or expand your operation's capabilities? Add a John Deere attachment. Our ever-expanding lineup includes over 100 models, so you're sure to find the right tool for the job.

Our **AH80 Bale Hugger** is perfect for transporting, stacking, and loading large round and rectangular bales. With a maximum load of 2,400 pounds, it's also ideal for handling 1,000-pound silage bags.

The bale hugger has a maximum opening of 110 inches. Its right- and left-hand arms close simultaneously, applying constant pressure to eliminate the risk of dropping or damaging bales. Durable round tubing helps prevent damage to bale wrappings/coverings.

Like all John Deere attachments, the bale hugger is optimized to work with Deere skid steers, compact track loaders, and compact wheel loaders equipped with a skid-steer-style Quik-Tatch™ coupler. It's also compatible with most competitive models. **See your local Deere dealer for details.**



MINNESOTA
 Burnsville
 Dayton *Opening 2020*
 North Mankato
 Marshall
 Moorhead
 Rochester
 Sauk Rapids

NORTH DAKOTA
 Bismarck
 Dickinson
 Grand Forks
 Minot
 Williston

SOUTH DAKOTA
 Aberdeen
 Rapid City
 Sioux Falls

MONTANA
 Billings
 Bozeman
 Great Falls
 Kalispell
 Missoula



**WANT IT?
 OWN IT.**

312GR SKID STEER

\$485 PER MONTH^{1,2}

\$540 WITH CAB

**INTRODUCING THE
 OWN IT OFFER**

Take advantage of the **OWN IT OFFER** and get special financing on select compact models that are easy on the wallet and tough on the job. You know you've always wanted Deere quality...now, **OWN IT**.



*Offer valid on qualifying purchases of new equipment made between 1 April 2020 to 31 October 2020. Subject to approved installment credit with John Deere Financial, for commercial use only. Down payment may be required. Average down payment is 10%. Taxes, freight, setup, delivery charges and optional features could increase monthly payment. Available at participating U.S. dealers. Prices and available models may vary by dealer. Offers available on qualifying purchases of new equipment purchased in the U.S. Prices and savings in U.S. dollars. ¹Qualified equipment includes the 312GR canopy package (0700) or cab package (0710) with 10x16.5 tires, vinyl mechanical suspension seat, seat belt (2" for canopy package and 3" for cab package), and 66" construction bucket. ²Qualified equipment includes the 316GR canopy package (0700) or cab package (0715 or 0745) with 10x16.5 tires, vinyl mechanical suspension seat, seat belt (2" for canopy package and 3" for cab package), and 66" construction bucket. ³Qualified equipment includes the 317G canopy package (0730) or cab package (0735) with 12.6" offset block lug tracks, vinyl mechanical suspension seat, seat belt (2" for canopy package and 3" for cab package), and 66" construction bucket. ⁴Qualified equipment includes the 317G canopy unit with a 12" bucket with teeth. ⁵Qualified equipment includes the 306 canopy or cab unit with an 18" bucket with teeth.